



40° RIGHT HAND 2 WALL GRAB RAIL WITH BACKREST

Description

Stainless Steel Right Hand 40° Angled Grab Rail with integrated Backrest. Backrest is site adjustable upon installation to ensure accurate location. Unit is accessible compliant when installed in accordance with AS1428.1-2009 (Amdt. 2010), and can withstand an applied force of 1100N in any direction when installed correctly.

Materials

Bar: #304 Stainless Steel tubing with satin finish, 32mm Dia.

Concealed Mounting Flanges: #304 Stainless Steel with multiple holes for attachment to wall.

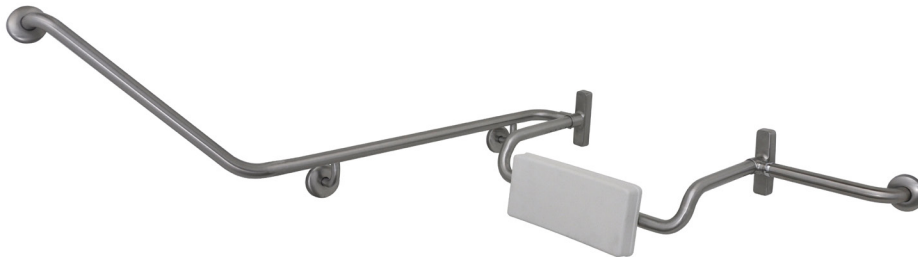

RBA4150-239 - 40° Angled 2 Wall Grab Rail With Polyurethane Backrest

Flange Cover: #304 Stainless Steel, clips over mounting flange to conceal fixing points.

Fixings: By others.

Related Product

RBA4150-240: Left Hand: 40° Angled Accessible Compliant Grab Rail with integrated Polyurethane Backrest

RBA supplies both 40° or 90°, 2 wall Grab Rails with integrated Polyurethane Backrests. For more information please see our website.

Installation

Grab Rails are no stronger than the anchors or walls to which they are attached and must be firmly secured in order to support the loads for which they are intended.

Important: Installation instructions and current rough-in details should be furnished with each fixture. Do not rough in without certified dimensions. Dimensions are subject to manufacturer's tolerance of +/-10mm.

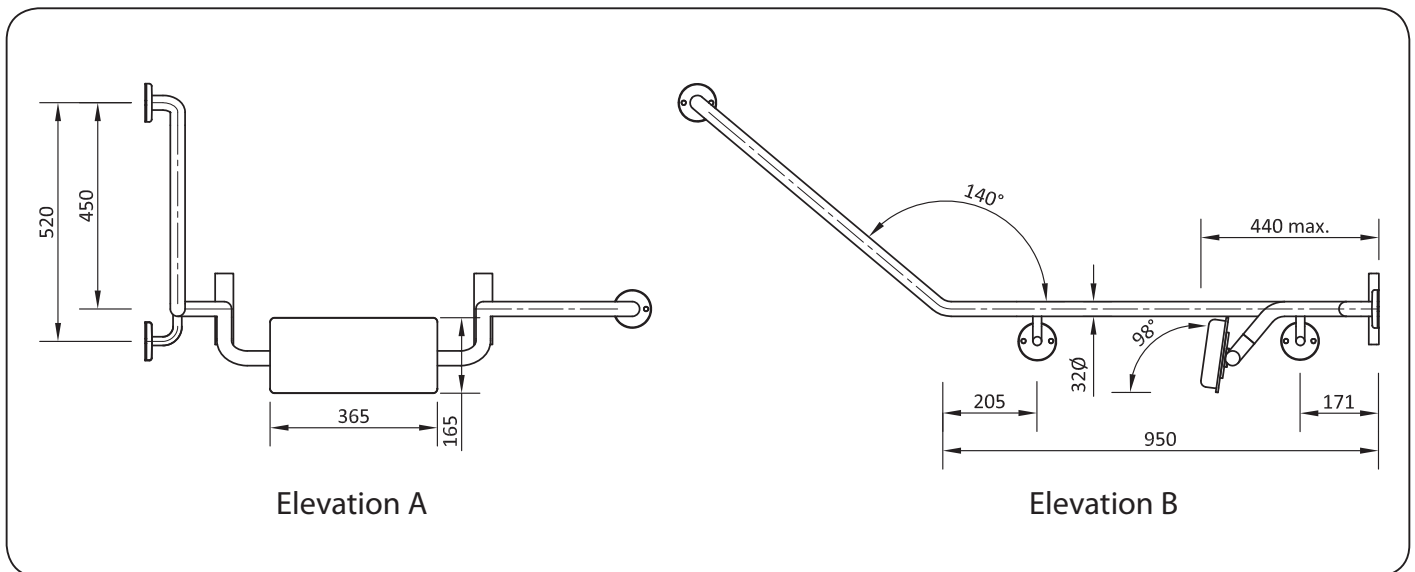

As improvements in the design and performance of RBA products are continuous, specifications may be subject to change without notice. The illustrations and descriptions herein are applicable to production as of the date of this Technical Data Sheet. Revised 08/14

© 2014 by RBA Group

TD/Model RBA4150-239/0814

SYDNEY • MELBOURNE • BRISBANE • PERTH • AUCKLAND

Australia 1300 788 778 • sales@rba.com.au • www.rba.com.au

New Zealand 0800 722 111 • sales@rbagroup.co.nz • www.rbagroup.co.nz